



SLIM

compact
sliding doors

LUCE S

The Luce S automatic sliding door operators are perfect for automatic pedestrian access points in areas with specific aesthetic or architectural requirements. With its ultra-compact supporting profile and cover, only 10 cm high, the operator works perfectly in any architectural context reducing the aesthetic impact to a minimum. Also available in single-leaf (up to 110 kg) or double-leaf (up to 70+70 kg) versions.

LUCE S



↓ download LUCE S instructions and certificates

www.myoneautomation.com

Operator for sliding doors with carriages designed to ensure that the doors are very stable and easy to adjust, both in height and depth. Reduced size system (only 10 cm high). The operator has a control unit with LED alphanumeric display, full-range switching power supply (100-240 V 50/60 Hz) and battery charger. The presence of a USB connector makes it quick and easy to update the firmware as well as to copy parameters and operating logics to a new system instantly. Continuous operation guaranteed.

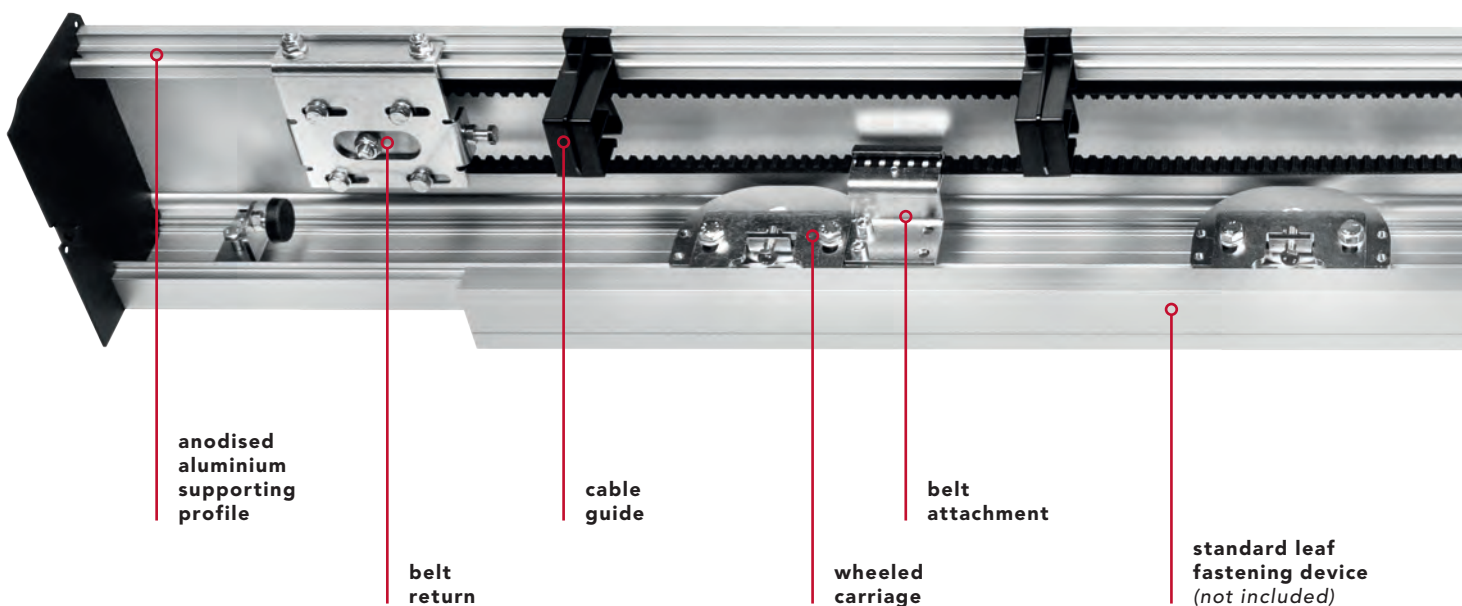

technical data

power supply	full range 100÷240 Vac 50/60 Hz
power consumption	70 W
power consumption in stand-by	3 W
accessories power supply	24 Vdc = / 1 A max
maximum speed 1 door	0.8 m/s
maximum speed 2 doors	1.6 m/s
maximum load 1 door	110 kg
maximum load 2 doors	70 + 70 kg
type and frequency of use	continuous operation = 100%
operating temperature	-15°C / +50°C
protection degree	IP20
data backup memory	USB flash drive



1 leaf
max. weight
110 kg



2 leaves
max. weight
70 + 70 kg

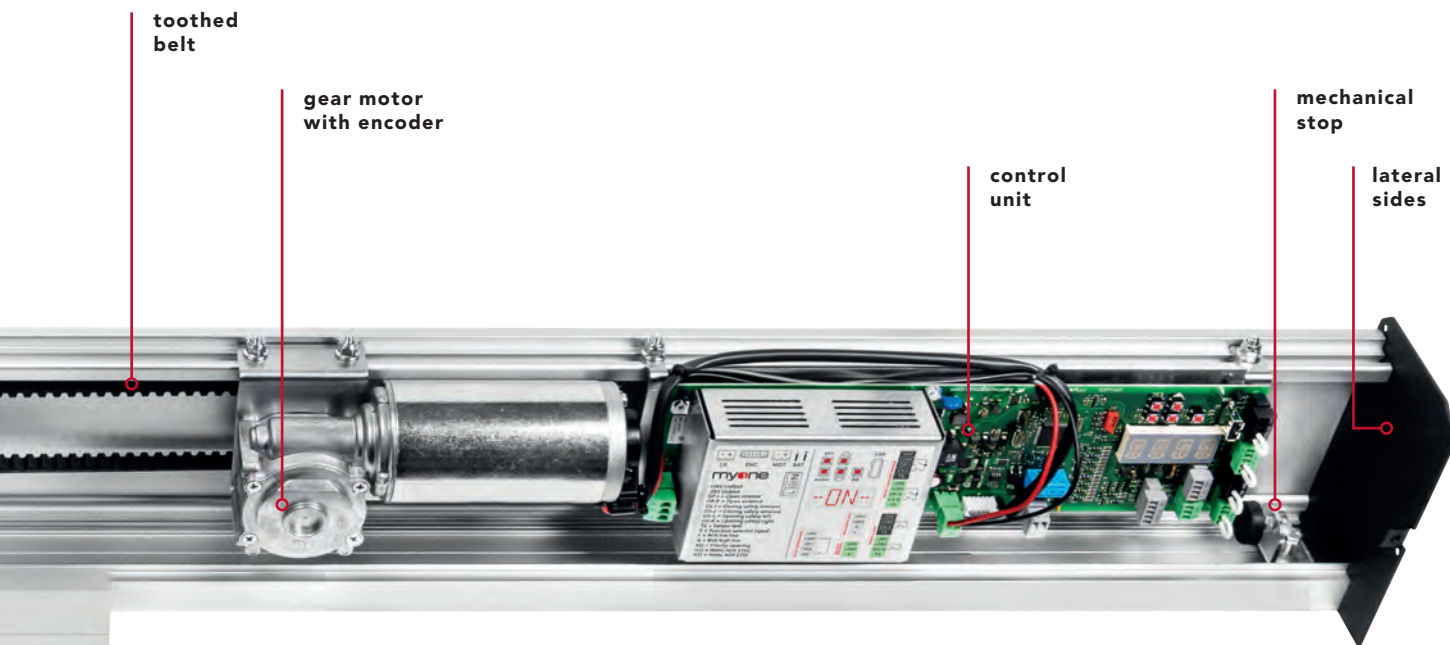

compact preassembled

*The values of the passage size (A) and of the leaf are indicative and include an overlap of around 50 mm.

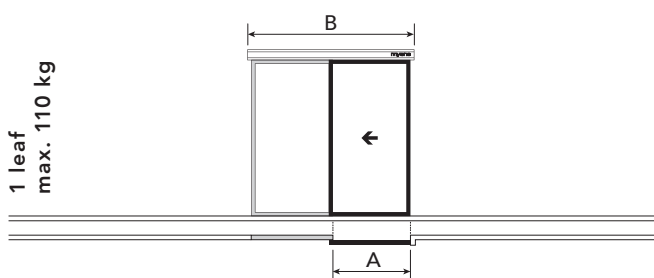

1 leaf
max. 110 kg

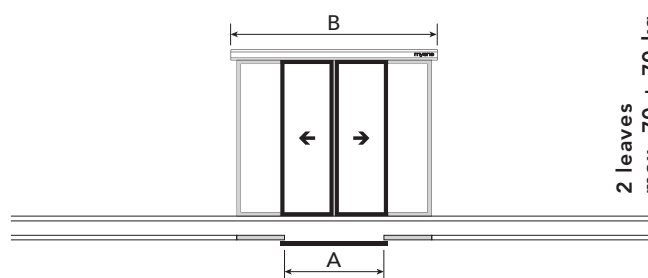

2 leaves
max. 70 + 70 kg

	A	B
LUCES1901S	900 mm	1900 mm
LUCES2101S	1000 mm	2100 mm
LUCES2501S	1200 mm	2500 mm
LUCES2901S	1400 mm	2900 mm
LUCES3301S	1600 mm	3300 mm
LUCES3701S	1800 mm	3700 mm
LUCES4201S	2000 mm	4200 mm
LUCES5001S	2450 mm	5000 mm
LUCES6501S	3100 mm	6500 mm

	A	B
LUCES1902S	900 mm	1900 mm
LUCES2102S	1000 mm	2100 mm
LUCES2502S	1200 mm	2500 mm
LUCES2902S	1400 mm	2900 mm
LUCES3302S	1600 mm	3300 mm
LUCES3702S	1800 mm	3700 mm
LUCES4202S	2000 mm	4200 mm
LUCES5002S	2450 mm	5000 mm
LUCES6502S	3100 mm	6500 mm

the preassembled operator is made up of:

control unit | gear motor with encoder | wheeled sliding carriages | anodised aluminium supporting profile and cover | belt return | mechanical stop | belt | cable guide | screw kit | lateral sides

kit for compact doors
with one sliding leaf

KLUC01S

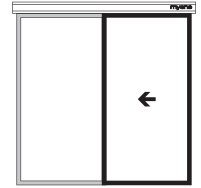

gear motor with encoder
and electronic control unit



belt
return

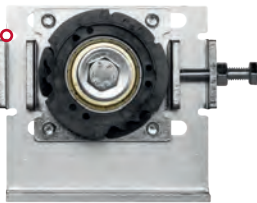

cable guides



sliding
carriages



mechanical
limit switch



belt connection



screw kit



lateral sides



LUCE S - accessories to complete the kit

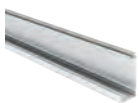

01AL0005

Anodised aluminium supporting profile.
- 2.75 kg/m



01AL0002S

Anodised aluminium cover.
- 1.25 kg/m



32CG0004

Belt.
- 1 m



32CG0001

Belt.
- 50 m



011M0007

Packaging kit with headers.

kit for compact doors
with two sliding leaves

KLUCE02S

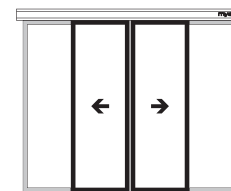

gear motor with encoder
and electronic control unit



belt
return

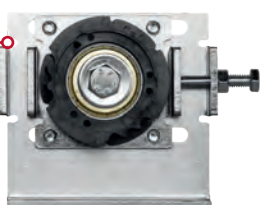

cable guides



sliding
carriages



mechanical
limit switch



belt connections



screw kit



lateral sides



LUCE S - accessories to complete the kit



01AL0005

Anodised aluminium supporting profile.
- 2.75 kg/m



01AL0002S

Anodised aluminium cover.
- 1.25 kg/m



32CG0004

Belt.
- 1 m



32CG0001

Belt.
- 50 m



011M0007

Packaging kit with headers.

framed door accessories - commercial frame

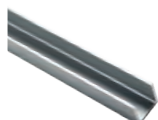

01AL0030 - 1000 mm
01AL0031 - 1500 mm
01AL0032 - 2000 mm
01AL0035 - 3000 mm

Aluminium floor guide for one leaf.



01FE0018
 Floor guide slider.



01AL0008 - 1000 mm
01AL0009 - 1500 mm
01AL0010 - 2000 mm
01AL0015 - 3000 mm
01AL0016 - 5670 mm
01AL0020 - 6500 mm

Standard leaf fastening device complete with fixing brackets for the carriage.



90RM0053
 Pair of leaf fixing brackets (1 leaf).

glass door accessories - fastening set for glass leaves with pre-drilled holes

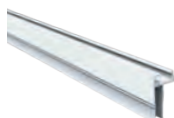

99AC0004 - 1000 mm
99AC0005 - 1500 mm
99AC0006 - 2000 mm
99AC0016 - 3000 mm
99AC0021 - 5670 mm
99AC0029 - 6500 mm

Fastening set for glass leaf (10-12 mm) with pre-drilled holes.



01FE0049
 Glass door slider.
 - 6 piece pack



01FE0050
 Glass door stainless steel slider.



01GM0001
 Adhesive gasket for glass leaf.
 - 6 m pack

glass door accessories - fastening clamp set for glass leaves



99AC0001 - 1000 mm
99AC0002 - 1500 mm
99AC0003 - 2000 mm
99AC0014 - 3000 mm
99AC0015 - 5670 mm
99AC0027 - 6500 mm

Fastening clamp set for glass leaf (10-12 mm thickness).



01FE0049
 Glass door slider.
 - 6 piece pack



01FE0050
 Glass door stainless steel slider.



01GM0001
 Adhesive gasket for glass leaf.
 - 6 m pack

accessories



99BA0005

Emergency battery kit with wiring and bracket.



99EB0007

Electromechanical lock kit for return with release cord.



01FE0059

Safe for external release.

operator cross-section
technical drawing

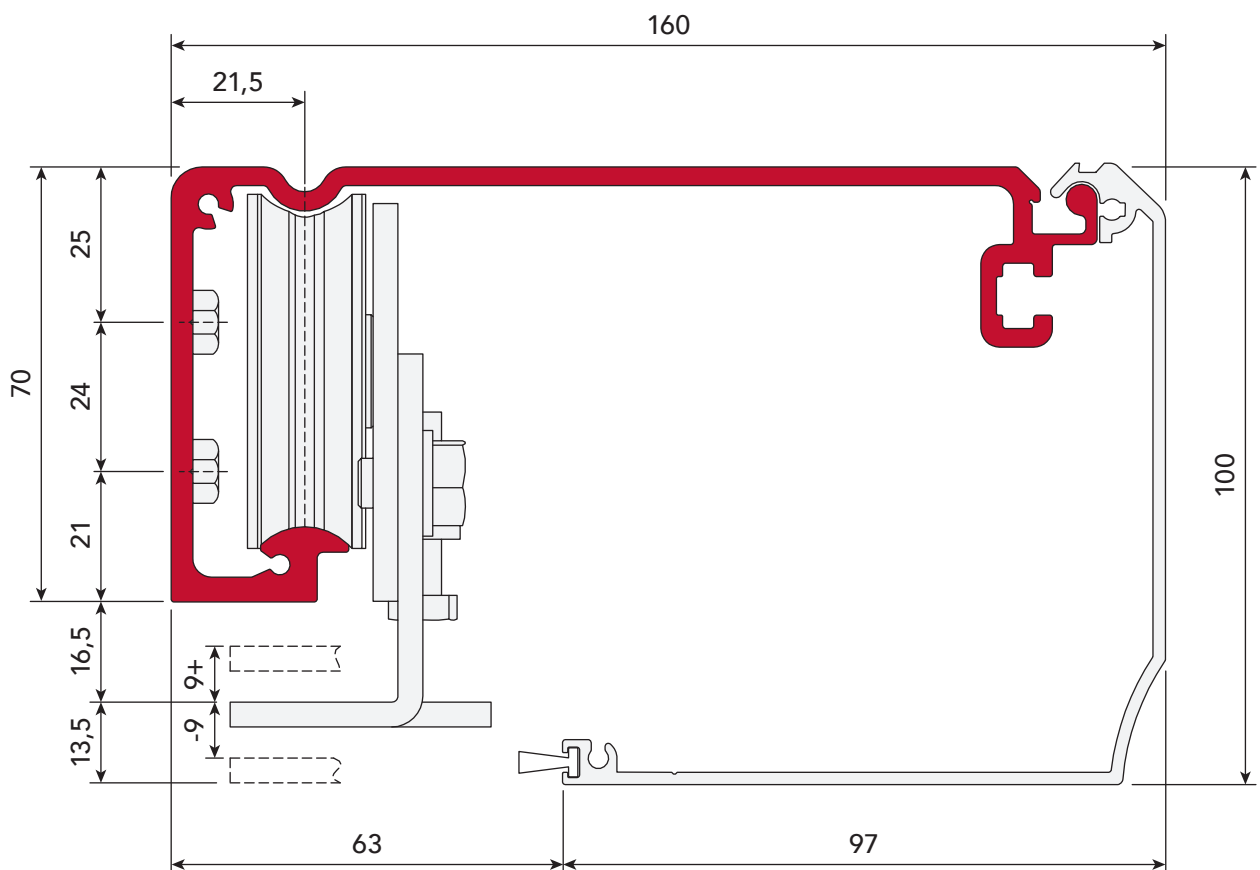

entrance with M30
myone frame

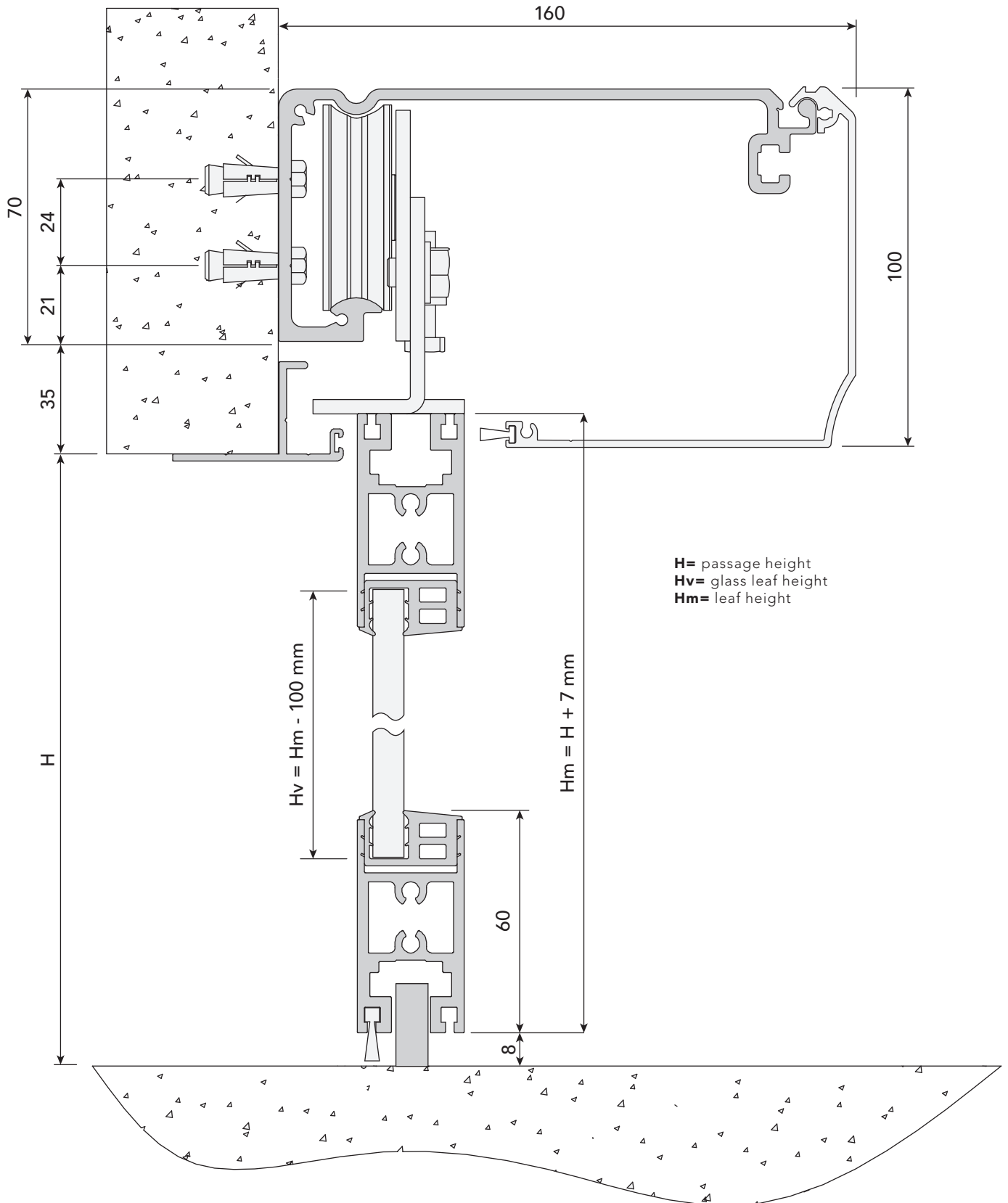

entrance with commercial profiles

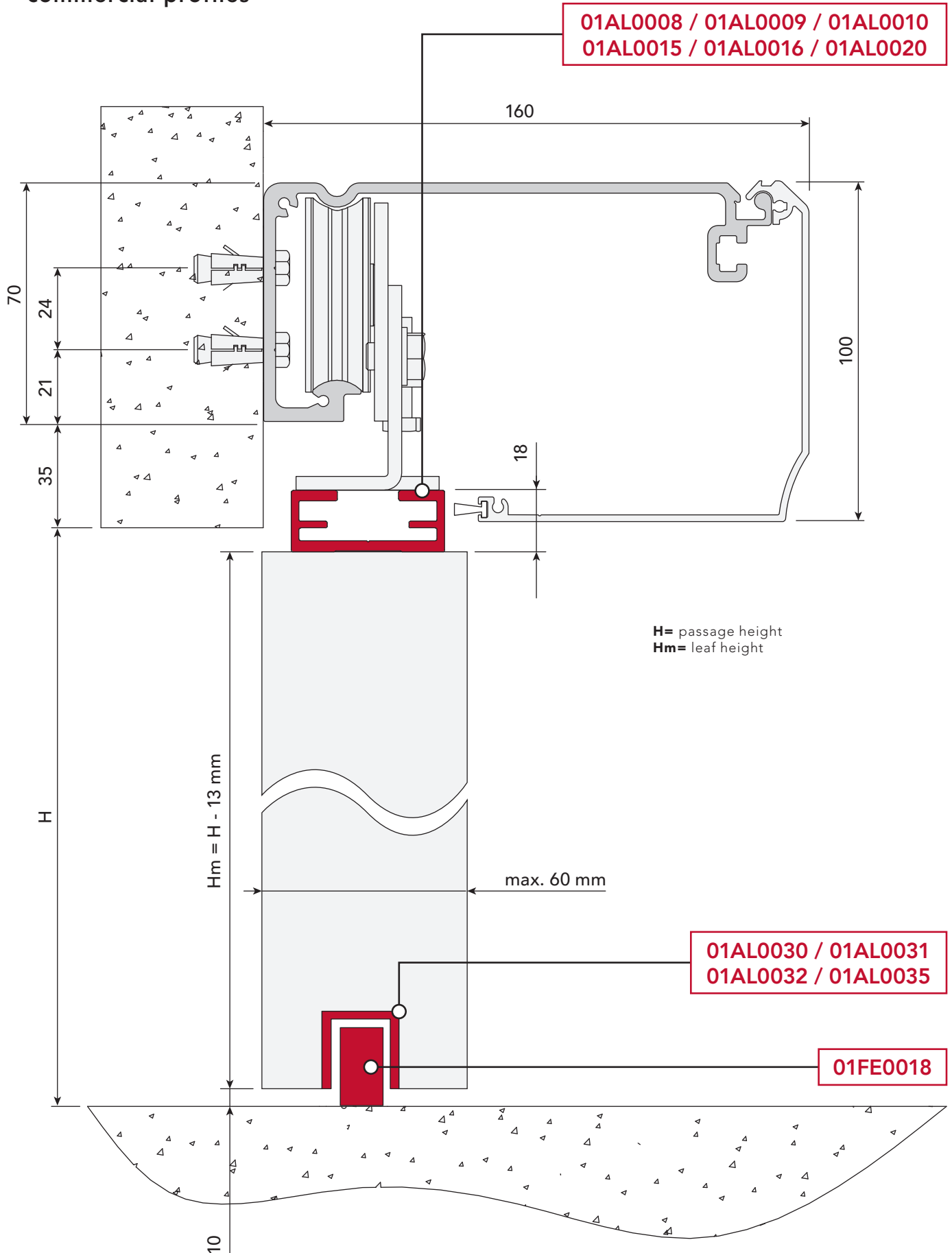

entrance with fastening set
for glass leaf with pre-drilled holes

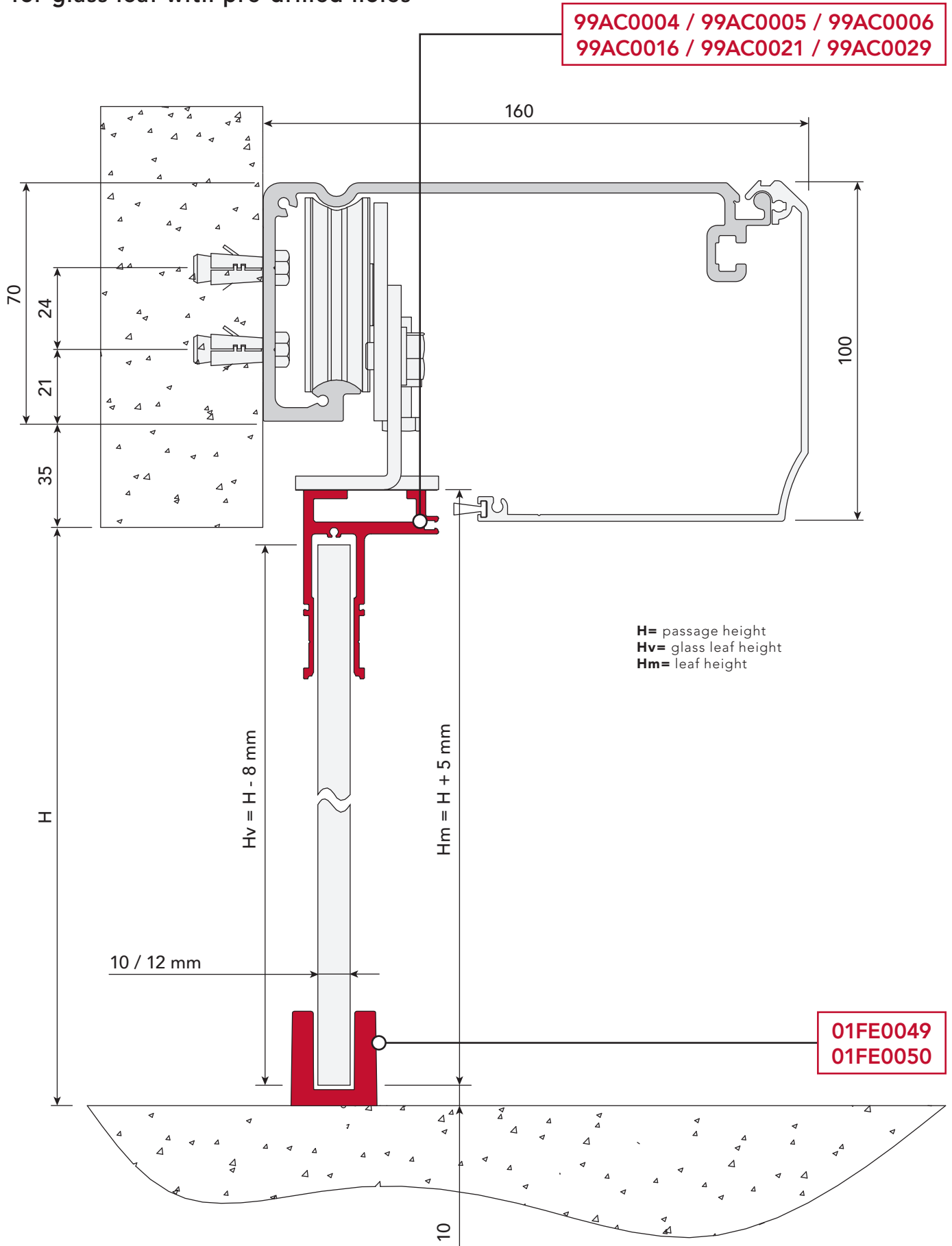

entrance with fastening set
for glass leaf to clamp

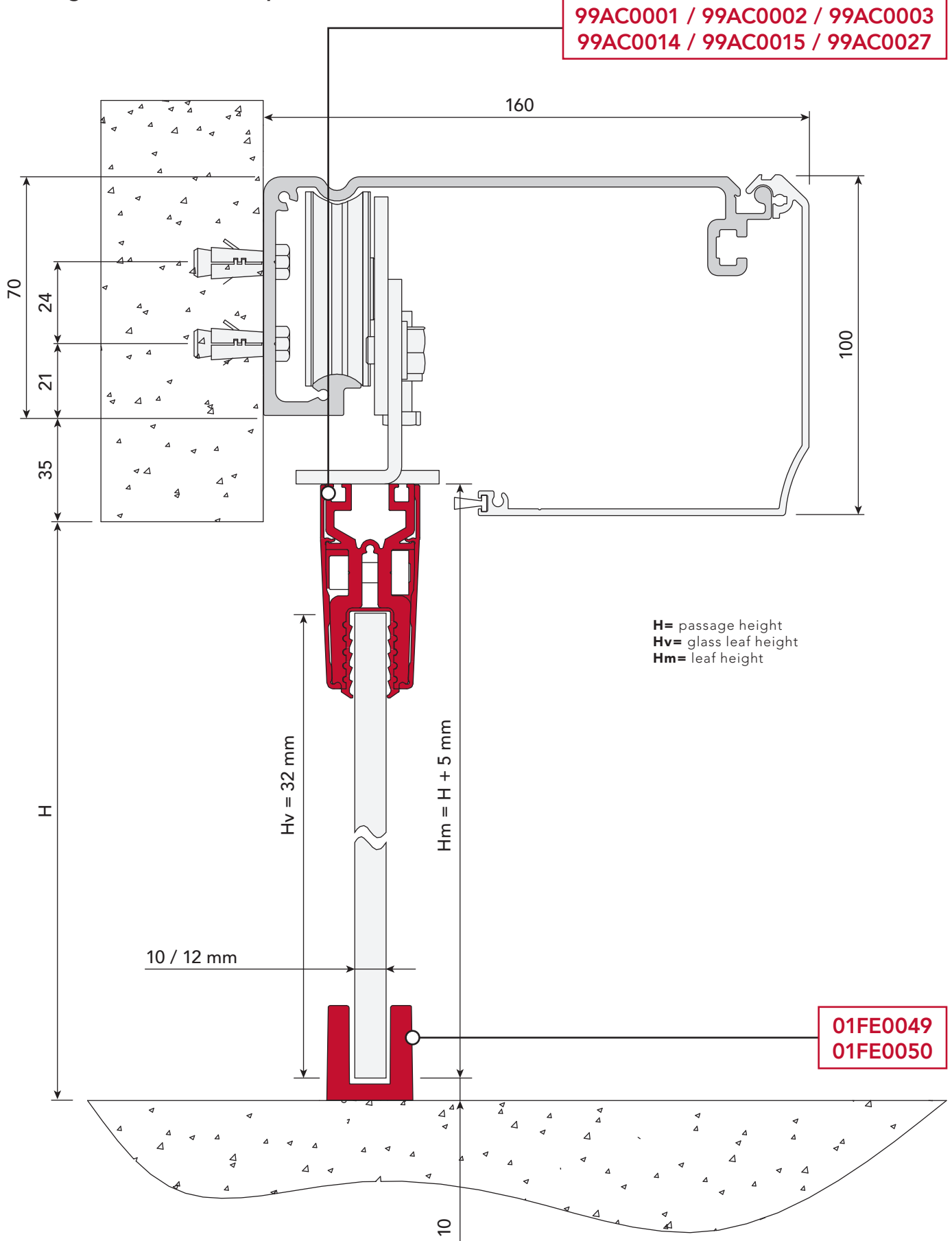

myone

MYONE S.r.l

Via Abbate Tommaso, 52
30020 Quarto D'Altino (VE) ITALY

T +39 0422 824384

info@myoneautomation.com
www.myoneautomation.com

Part of the Benincà family

BENINCA
GROUP